

UPC·MARATHON

ENDOINJECTOR™

Endothermic Generator Control System Installation and Operation Manual



CONNECT WITH US



MASTERING
STRENGTH.
WORLDWIDE.



MANUAL #: 417

Revision #	Revision Date	Revision Description
003	October 25, 2019	

THIS MANUAL IS SUPPLIED ELECTRONICALLY.

COPYRIGHT^(C)

No part of this publication may be reproduced, transmitted, transcribed, stored in a retrieval system, or translated into any language or computer language, in any form or by any means, electronic, mechanical, magnetic, optical, chemical, manual, or otherwise, without prior written permission of United Process Controls Inc. (UPC-Marathon).

The information contained in this document is STRICTLY CONFIDENTIAL and PROPRIETARY to UPC-Marathon, and shall not be: i) reproduced or disclosed in part or in whole, ii) used for any design or manufacturing of heat treating and/or control equipment, or any other purpose except for that which it is supplied under the terms of the Contract, unless the express written authorization is obtained from UPC-Marathon.

Drawings and photographs included in the documentation are the property of UPC-Marathon, and it is strictly forbidden to reproduce them, transmit them to a third party, or use them for manufacturing and/or design of equipment. Sub-licensing of any technical information contained in this Documentation is strictly forbidden under the terms of the Contract.

UPC-Marathon reserves the right to modify this document without prior notice.

DISCLAIMER:

The **EndoInjector™** is to be used by the industrial operator under his/her direction. UPC-Marathon is not responsible or liable for any product, process, damage or injury incurred while using the **EndoInjector™**. UPC-Marathon makes no representations or warranties with respect to the contents hereof and specifically disclaims any implied warranties or merchantability or fitness for any purpose.

WARRANTY:

UPC-Marathon warrants its goods as being free of defective materials and faulty workmanship. Contact your local sales office for warranty information. If warranted goods are returned to UPC-Marathon during the period of coverage, UPC-Marathon will repair or replace without charge those items it finds defective. The foregoing is Buyer's sole remedy and is in lieu of all other warranties, expressed or implied, including those of merchantability and fitness for a particular purpose. Specifications may change without notice. The information we supply is



believed to be accurate and reliable as of this printing. However, we assume no responsibility for its use.

TECHNICAL ASSISTANCE

For all questions or concerns regarding the operation of the **EndoInjector™**, please consult the last page of this manual for contact information.



Table of Contents

1	DESCRIPTION.....	5
1.1	Mixing System	5
1.2	Dew Point Control.....	5
1.3	Temperature Control	5
1.4	Paperless Chart Recorder	5
1.5	Custom Designed System	6
2	SPECIFICATIONS	6
2.1	Modbus Communication.....	6
2.2	Data Storage	7
2.3	Electrical Component Overview.....	7
3	MECHANICAL COMPONENT OVERVIEW.....	8
3.1	Installation Notice	9
3.2	Mechanical Installation	9
3.3	Electrical Installation.....	11
4	MAINTENANCE.....	13
5	SCREEN OVERVIEW	14
5.1	Process Screen Overview	14
5.2	Setup Screen Overview	17
5.3	Language Setup Parameter Group (<i>USER, ADMIN, ENG Levels</i>).....	22
5.4	Paperless Chart Recorder	22
5.5	Alarm Status Screen.....	24
5.6	Recipe Screen	26
6	CUSTOMER SUPPORT	27



1 DESCRIPTION

1.1 Mixing System

The EndoInjector™ is a precision gas mixing system and endothermic gas generator control system integrated into one package. The patented EndoInjector™ mixing system designed by UPC utilizes electronic flow measurement and a precision gas injection valve to constantly monitor and control the ideal gas mixture required to generate high quality endothermic gas.

The EndoInjector™ incorporates the latest technology in regenerative blower design that is capable of significant turndown for single and multi-retort generators. When combined with the patented mixing system, the EndoInjector™ delivers flow on demand throughout the working range of any generator down to 20% of rated capacity or 5% rated capacity with an extended turndown package. This feature eliminates endothermic gas waste during production while maintaining the precise gas mixture and ratio adjustment capability required to control gas quality throughout the turndown range.

1.2 Dew Point Control

The integrated dew point control logic of the EndoInjector™ will monitor the endothermic gas quality then precisely modify the air gas mixture to control the quality of the endothermic gas. The sensor required to monitor this gas is not included with the EndoInjector system but can be purchased separately from UPC. The EndoInjector™ control system is also capable of utilizing CO₂ or other control variables. Contact UPC for more information.

1.3 Temperature Control

The integrated temperature control logic of the EndoInjector™ will monitor a single temperature zone or multiple temperature zones and provides an output (relay or signal) that can be used to accurately control the temperature of any endothermic gas generator. The thermocouple required to monitor temperature and valves required to control temperature are not included with the EndoInjector™ system but can be purchased separately from UPC. The EndoInjector™ control system is also capable of utilizing CO₂ or other control variables. Contact UPC for more information.

1.4 Paperless Chart Recorder

The EndoInjector™ integrates a full-color touch-screen paperless chart recorder to monitor all critical process variables of an endothermic gas generator. The data and backup files are stored and maintained on the touch-screen in an encrypted format for a period of 5+ years. The data can be exported to CSV format for easy review within a spreadsheet application (i.e. MS Excel or similar).



1.5 Custom Designed System

The EndoInjector™ is a precision mixing system that is assembled, calibrated, and fully tested to perform to the exact requirements of a specific endothermic gas generator. The system is not designed to be interchangeable with any other generator without written approval of the new generator application from UPC.

2 SPECIFICATIONS

Maximum Flow Capability Calibrated to Order – Indicated on System Specifications Plate
 Minimum Flow Range..... 20% of Maximum Flow
 Temperature Limits 32°F to 130°F
 Flow Meter Pressure Limits..... 5 psig maximum
 Inlet Gas Supply Pressure..... 0.25 - 3 psig (min-max)
 Control Power Required 85-264VAC (50/60 HZ)

Horsepower 1.0 HP
 Power Supply 3 Phase 230/460 VAC 50/60 Hz
 Power Required 0.75 kW

Horsepower 2.0 HP
 Power Supply 3 Phase 230/460 VAC 50/60 Hz
 Power Required 1.5 kW

Horsepower 3.0 HP
 Power Supply 3 Phase 230/460 VAC 50/60 Hz
 Power Required 2.23 kW

Horsepower 4.0 HP
 Power Supply 3 Phase 230/460 VAC 50/60 Hz
 Power Required 2.98 kW

Horsepower 5.5 HP
 Power Supply 3 Phase 230/460 VAC 50/60 Hz
 Power Required 4.1 kW

2.1 Modbus Communication

Standard communication between the HMI and the control system is handled via ModbusRTU (RS232 or RS485) or ModbusTCP/IP (Ethernet) as required. Additional communications ports are available but can vary by type depending on the control system specified when ordering and provided with the system. A Modbus register address list and other communication details



are provided as an attachment to this manual. Contact UPC support team with any questions regarding communication setup of this device.

CAUTION: Remote Connection Considerations

Connection of industrial equipment to a remote network opens the system to security and safety vulnerabilities. Access to any industrial equipment including the EndoInjector™ over a network must be strictly controlled so that only those trained in the operation of the equipment can modify parameter values within the system. Further, precautions should be integrated to prevent parameters from being modified accidentally and set to values outside of safe ranges.

2.2 Data Storage

The HMI touchscreen includes a minimum of 7GB of unused internal hard drive space. The EndoInjector™ daily encrypted log files are contained within the AEC log directory and a backup file is located in a backup directory. The combined daily file size will consume approximately 300KB per day. Therefore, the actual capacity of the hard drive will be able to maintain over 60 years of log data. However, due to memory life considerations the process log data integrity should be considered maintained locally at the machine for a period of 5+ years. Of course, the actual data may last longer and can be backed up remotely for an indefinite period.

2.3 Electrical Component Overview

The EndoInjector™ mixing system can be supplied with several different types of controllers depending on customer specifications and specific generator control requirements. The electrical components that are not part of the mechanical assembly are typically packaged separately and found in a box that accompanies the system. Refer to the electrical wiring diagram and material list attached to this manual and ensure that each item detailed in the attached drawing is accounted for and has not experienced physical damage during shipment prior to proceeding with the installation.



3 MECHANICAL COMPONENT OVERVIEW

Every EndoInjector™ contains many individual components that are calibrated, and fully tested to perform as a complete system. The components can be supplied preassembled or as separate sub-assemblies depending on the installation requirements. The diagram(s) below detail the main critical mechanical components of the system. Review each critical component and ensure there is no physical damage to these components during shipping before proceeding to install the system.

(LP) Configuration Overview

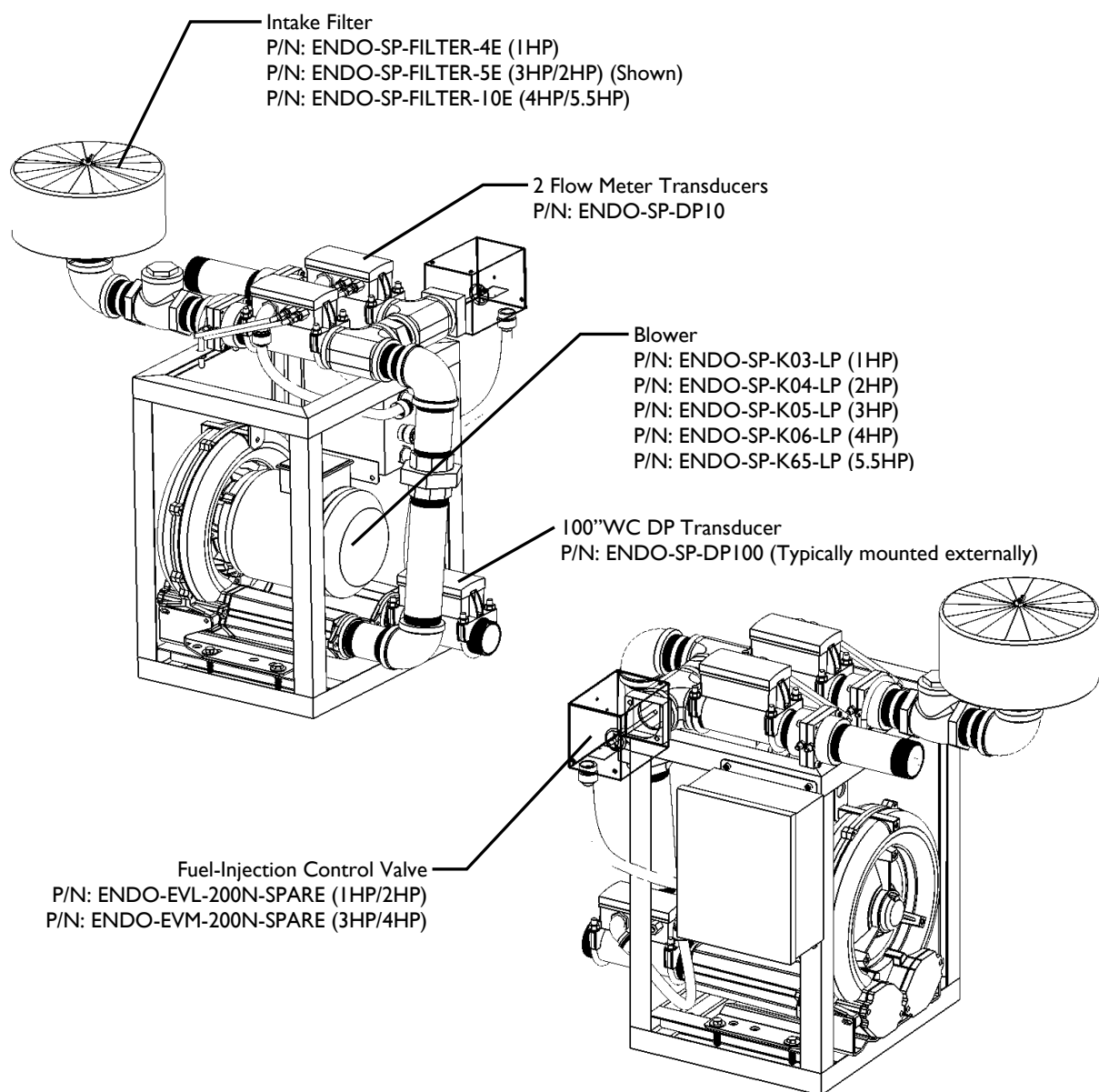



3.1 Installation Notice

Only qualified personnel experienced with endothermic gas generator operation and safety requirements shall perform an EndoInjector™ installation. It should be noted that additional mechanical components and interlocks will be required on the generator other than those supplied with the EndoInjector™ system to ensure the generator is safe and meets NFPA 86 (or similar) guidelines.

The EndoInjector™ is a robust industrial device however; some precision measurement components may be susceptible to damage from severe shock. Care should be taken to handle the system during the installation process. The system was not designed to support personnel and should not be used as a step or a support as this could damage components on the system and may cause injury.

3.2 Mechanical Installation

Installation Procedure (Refer to pipeline diagram attached to manual for proper installation)

1. Inspect the mixing system for any damaged or missing components and confirm each component detailed in the “Mechanical Component Review” section of this manual is accounted for based on the configuration provided.
2. Make note of the following locations on the mixing system and consider the best location for the mixing system on the generator to accommodate the piping and access requirements to reach these locations:
 - a. Gas Supply Inlet
 - b. Mixed Gas Outlet
 - c. Air Intake Filter
3. Secure the mixing system to the generator frame using mounting holes on the base of the system. If retrofitting a generator, the old carburetor motor location is typically a suitable location. The mixing system should be mounted level and should be reasonably insulated from direct radiant heat sources.
4. Attach the reaction gas supply pipeline to the gas inlet on the mixing system. The gas supply must be pressure regulated to a minimum of 0.5 psig and a maximum of 3 psig. Note that the reaction gas piping must contain the required interlocks and components to meet NFPA 86.
5. Attach the mixed gas outlet to an appropriate automatic fire check valve and install a low-pressure air switch to confirm blower operation.
6. Install the Outlet Pressure Transducer to a sense line attached to the generator outlet (after the cooler(s) but before any valves).



7. Install Air Intake Filter.

The following connections shall be made as described.

(LP) Configuration

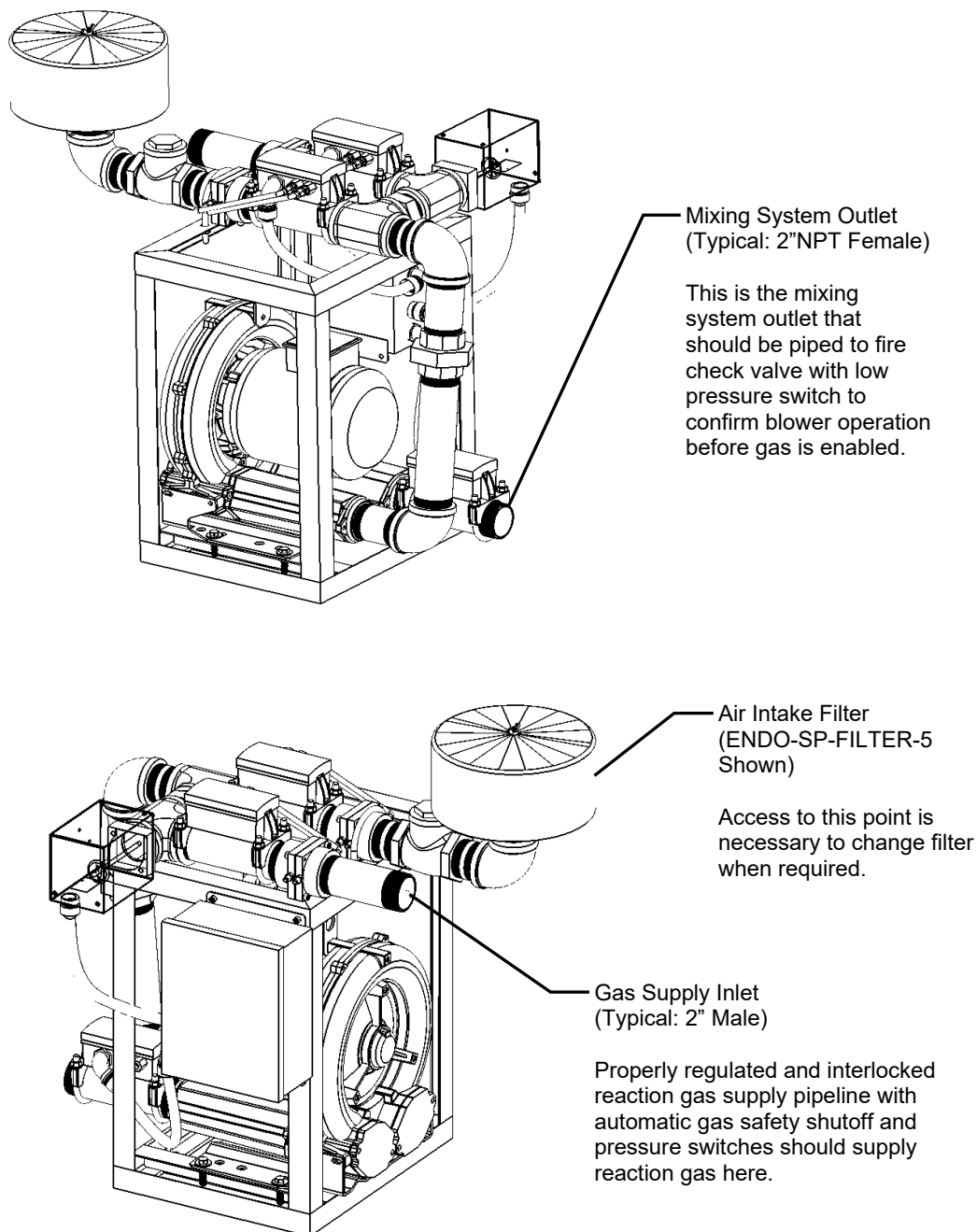



3.3 Electrical Installation

It is important to note that there are many different generator manufacturers and the wiring designs and control logic can be very different depending on the manufacturer and age of the generator. Only a qualified electrician experienced with endothermic gas generator operation and current safety requirements shall perform an EndoInjector installation. Proper safe electrical interlocks must be designed to meet safe generator operation based on NFPA86 guidelines. If necessary, installation supervision and direction of turnkey installation services are available from UPC certified installation professional. The primary consideration is that the EndoInjector™ control system is designed to provide the temperature control, dew point control, and air gas ratio control of an endothermic gas generator. Basic electrical installation includes:

1. Mount the industrial touch-screen HMI supplied with the system into generator control enclosure and ensure the screen is protected from close proximity to direct radiant heat sources or other excessive heat. Ensure proper cutout and do not force into cutout or over tighten mounting brackets as it may deform the touch-screen and cause the touch panel to malfunction. Please refer to the electrical wiring print supplied with the EndoInjector™ system for proper HMI cutout sizing.
2. Mount the 24VDC power supply, process controller, and relays supplied with the EndoInjector™ system inside the controls enclosure. If retrofitting to existing generator it is typical to remove temperature and dew point controllers installed on generator. However, it is important to make detailed notes of wiring numbers and their purpose so that final terminations can be made with the EndoInjector™ control system.
3. Wire the EndoInjector™ blower motor.

IMPORTANT

Make sure to check the terminal jumpers inside the motor wiring box and confirm they are positioned properly for the voltage being supplied. (Note: To reduce electrical noise in the DC circuits, it is recommended that the high voltage motor wiring should be in a separate Shielded SOOW Cord. Or a separate conduit.)

IMPORTANT: The EndoInjector™ Blower is a gas train component. SOOW cord or fully sealed conduit with cemented ends must be used to maintain a gas tight electrical connection.

4. Wire the mixing system control components together as shown on the attached installation wiring diagram. This wiring diagram only details the control system assembly and integration between mixing system, HMI, and sensors. The wiring diagram and does not detail the required integration wiring between the control system and the generator panel and components. This is because the integration wiring and wire numbers will be dependent on the manufacturer and age of the generator equipment. It



is important to have a detailed wiring diagram of the generator to use as a guide to locate wire numbers and terminal locations required for proper EndoInjector™ installation and safe generator operation. After the wiring detailed on the attached installation diagram is completed, review the following check list as a guide to ensure proper integration of the relays and control outputs are made to the generator.

- a. Critical Alarm Relay (System Enable): The critical alarm relay is only energized when all internal checks and ratio control system confirms system is ok to start. If there is a critical failure this relay will be de-energized. Therefore, it is typical to wire a normally open contact on this relay in series with the low temperature alarm relay. This relay is specific to the EndoInjector™ system and will not be part of existing generator wiring.
- b. Temperature Control Output: The EndoInjector™ provides both a relay for time proportional control and a 4-20mA signal output for heat control. Either of these outputs can be used to integrate existing heat control components to control the temperature of the generator. The time proportional relay energizes when calling for more heat. The 4-20mA signal increases when calling for more heat.
- c. Non-Critical Alarm (optional): The Non-Critical alarm relay is simply a deviation alarm relay that will energize when a temperature, dew point, or ratio deviation alarm occurs. The relay will only de-energize when all deviation alarms are ok. Therefore, a horn silence circuit will be required if using this relay to sound a horn.
- d. Horn Output (optional): The horn output is provided on some systems in replacement of the “Non-Critical” alarm. If a horn output is provided, this output is energized when any alarm is present and will de-energize after the silence horn contact is made.
- e. Probe Burnout Relay: The probe burnout relay energizes when requesting a zirconia probe to perform a burnout cycle. The relay will remain energized during the entire probe burnout time (see operation for setting) and then de-energize until the next probe burnout.
- f. Dew Point Wiring: When using a zirconia oxygen sensor to monitor dew point, be sure to wire both the thermocouple and mV signal wire to the controller as detailed on the wiring diagram.
- g. Temperature Control Wire: A thermocouple (Typically: K or S Type) should be wired to the temperature control input of the EndoInjector™ controller. Note that the control thermocouple must be separate from the Over and Low Temperature safety thermocouple.



4 MAINTENANCE

The LP EndoInjector™ is designed as a very robust industrial mixing system and the control logic is setup to monitor critical system faults before damage can occur. However, there are a few recommended items to check regularly on the mixing system to ensure successful system operation over many years.

Intake Air Filter

The intake air filter is the main item of concern that must be checked regularly and changed preemptively to ensure that the blower motor is not overheated or damaged. UPC installs a filter change indicator next to the intake air filter that should be inspected weekly and when the filter change indicator reaches the “RED ZONE” then the filter element should be removed, blown off/cleaned, and then replaced. After resetting the filter change indicator, continue to watch the filter change indicator. If the filter change indicator reaches the “RED ZONE” again then the filter element should be changed. Filter change times will range between monthly to every 6 months depending on the air quality in the room where the EndoInjector™ is located. In some circumstances, it may be advisable to pipe the incoming air from a separate location.

NOTICE

Running the blower with the filter change indicator in the “RED ZONE” for an extended period can cause offset in flow transducer readings and will cause the blower to overheat and can cause damage to the blower bearings and motor.

EndoInjector™ Blower Fan

The Blower of the mixing system has an integrated fan and cooling fins to help keep the motor from overheating during operation. It may be necessary to clean the fan protective guard and cooling fins of the motor with compressed air to prevent build up dirt/dust/oil. Failure to do so may result in reduction of the motor’s ability to cool itself and cause premature failure of the motor.

Generator Catalyst Burnout Procedure

Important: There has been a “history” of burning generators out on a regular interval (weekly, monthly). However, it is strongly recommended to only burnout generator catalyst when the percentage of un-reacted methane is unacceptably high (0.25 to 1.0%). Performing a burn out on a generator that does not require it can significantly reduce the life of the catalyst and retort. If a methane sensor is desired please contact UPC for further information.

1. A Burnout can be initiated via the “Recipe” screen on the ActiveHMI. The steps below should be followed to ensure a proper burnout procedure.
 - a. Stop the EndoInjector Blower.
 - b. Close the reaction gas manual valve.
 - c. On the HMI, navigate to the “Recipe” screen
 - i. Login at the top right corner with either the USER or ADMIN Password



- ii. Press the “SELECT” button at the top right, choose the desired recipe and press “LOAD”.
- iii. Send to PLC.
- iv. Start the burnout recipe by hitting the “Start” button at the top right.

5 SCREEN OVERVIEW

5.1 Process Screen Overview

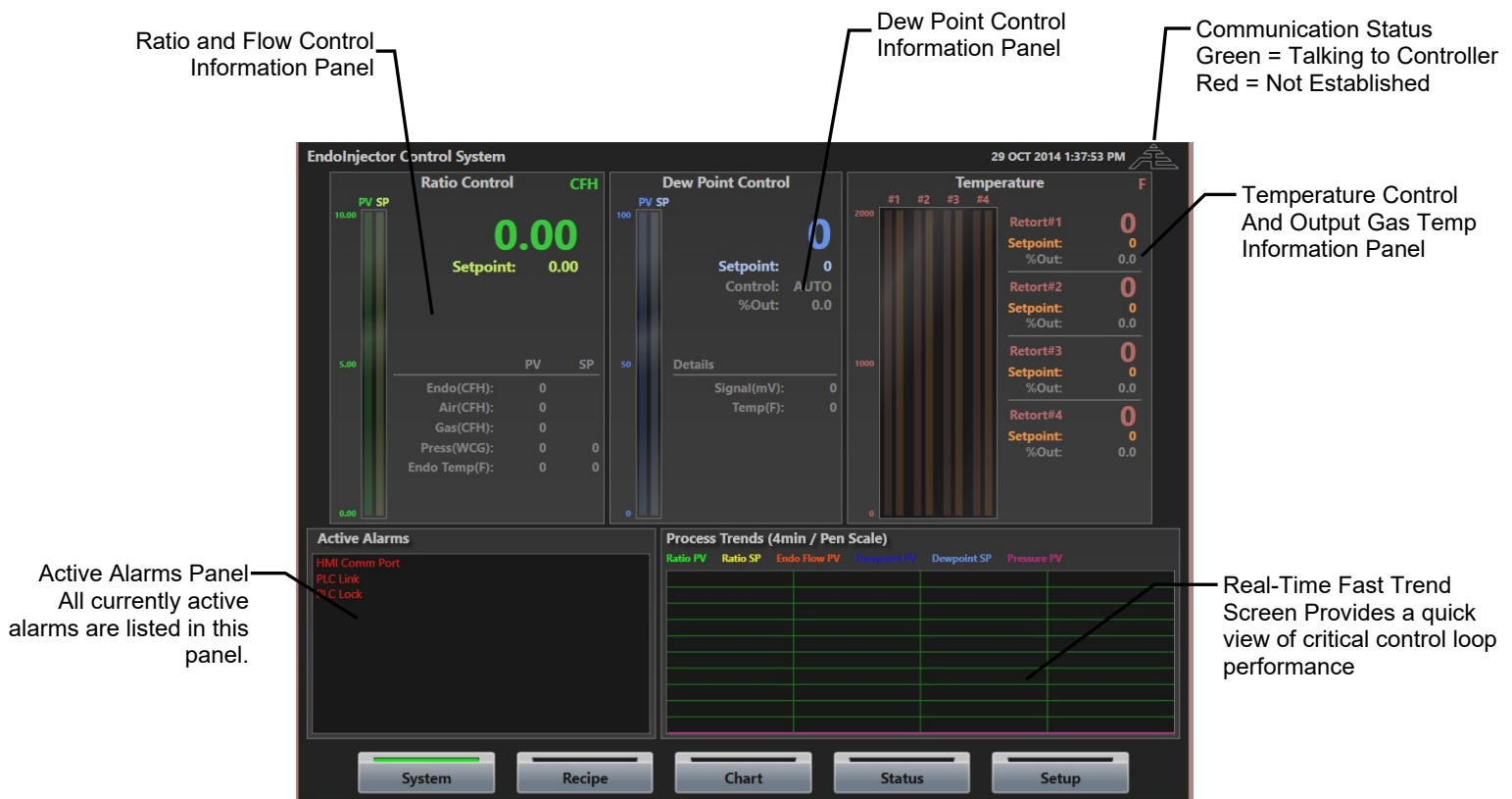

Ratio and Flow Control Panel

The ratio and flow control panel provides detailed information regarding the mixing system operation. Note: The bar graph scales are dependent on the pen scales defined within the paperless chart recorder and can be changed using the “edit pen” button on the history screen.

Air/Gas Ratio is the currently measured air flow divided by the currently measured gas flow passing through the mixing system. This value represents the actual mixture of air and gas being introduced into the gas generator and is directly correlated to the dew point of the endothermic gas produced. The actual ratio is controlled to the “Ratio Setpoint” by the



fuel-injection control valve. It should be understood that a higher ratio will produce endothermic gas with a higher dew point.

Ratio Setpoint is the desired mixture of air and gas that should be introduced into the generator. This value can be entered manually or can be controlled automatically by the dew point PID loop output. When controlled automatically, the operator must provide a minimum and maximum ratio setpoint so that the dew point control loop can only change the loop by a limited range.

Endo Flow is a calculated value that represents the amount of endothermic gas being produced by the generator. It is calculated using the following equation: $\text{Endo Flow} = (\text{Air Flow} + \text{Gas Flow}) \times (\text{Expansion Factor})$

Air Flow is the actual calibrated measurement of air passing through the EndoInjector™ mixing system. This value is measured using the air flow transducer mounted to the mixing system. A calibration curve detailing the transducer performance in relation to the factory calibrated flow measurements is attached to this manual. The air flow meter has integrated test ports that can be used to certify the meter calibration while in operation.

Gas Flow is the actual calibrated measurement of gas passing through the EndoInjector™ mixing system. This value is measured using the gas flow transducer mounted to the mixing system. A calibration curve detailing the transducer performance in relation to the factory calibrated flow measurements is attached to this manual. The gas flow meter has integrated test ports that can be used to certify the meter calibration while in operation.

Endothermic Gas Pressure indicates the generator output endothermic gas pressure based on pressure transducer.

Endo Temp (Optional) indicates the endothermic gas pressure as well as the alarm setpoint.

Dew Point Control Panel

The dew point control panel provides detailed information regarding the quality of the endothermic gas being produced by the gas generator. Note: The bar graph scales are dependent on the pen scales defined within the paperless chart recorder and can be changed using the “edit pen” button on the history screen.

Dew Point is the actual dew point of the endothermic gas being produced. The dew point is typically measured by taking a sample of endothermic gas and introducing it to either a zirconia oxygen sensor (probe) or a gas analyzer.

Dew Point Setpoint is the desired dew point that should be produced by the endothermic gas generator. This value is typically entered manually by the operator. The dew point of endothermic gas is directly correlated to the resulting “%Carbon” level within a heat-treating



furnace. While the dew point will not exactly predict %Carbon inside a furnace, because there are many other variables that determine the %Carbon value in a heat-treating furnace, but generally a higher dew point will result in a lower %Carbon value inside a heat-treating furnace (all other furnace variables being equal).

%Output value represents the PID control output signal used to change the air/gas ratio setpoint. If the %Output is equal to 100% then the air/gas ratio setpoint will be equal to the maximum air/gas ratio setpoint provided by the operator. If the %Output is equal to 0% then the air/gas ratio setpoint will be equal to the minimum air/gas ratio setpoint. The corresponding values between 0-100% will result in a linear change to the air/gas ratio setpoint.

Sensor Signal is the actual measured signal from the dew point sensor. This value is used to determine the dew point of the endothermic gas sample.

Sensor Temperature (*for probe sensors only*) is the actual measured temperature of the gas sample within the dew point sensor. This value is used to determine the dew point of the endothermic gas sample.

Temperature Control Panel

The temperature control panel provides detailed information regarding the temperature of the endothermic gas generator. The temperature panel is expandable to 4 separate temperature control loops that can be simultaneously viewed within this panel. Note: The bar graph scales are dependent on the pen scales defined within the paperless chart recorder and can be changed using the “edit pen” button on the history screen.

Temperature is the actual temperature within the hot zone of an endothermic gas generator. This value is measured by an industrial thermocouple. Note: a value of 2999 means that there is an open loop on the thermocouple input and the thermocouple is either not wired correctly or has failed.

Temperature Setpoint is the desired temperature within the hot zone of an endothermic gas generator. This value is typically set by the generator operator to a value of 1900degF or 1950degF for normal generator operation.

%Output value represents the PID control output signal used to control the temperature of the generator. The actual output can be either a time proportional (relay type) control or a 4-20mA control signal. If the temperature is lower than the temperature setpoint then the %output will increase. The increase in %output will result in the temperature control relay being energized “more often” and also result in the 4-20mA signal to increase in current.

Process Control Trend Panel



The process control trend panel is updated every second to display actual control characteristics of the mixing system that might not be seen on the one-minute storage interval of the historical log found in the paperless chart recorder. The trend panel is not the same as the paperless chart recorder in that all the data is updated much more quickly (1 second intervals) and the trend data is not stored longer than 4 minutes. The primary function of the trend panel is to provide real time feedback of system operation to better tune and confirm minimal control oscillations during system operation.

Trend Panel Setup: Double tapping on the trend title will display the trend pen selection menu. Select a value to display for each pen and close the setup screen. Changes are immediate. Note: The trend pen scaling and color is dependent on the setup for those values within the paperless chart recorder and can be changed using the “edit pen” button on the chart screen.

Active Alarm Panel

The active alarm panel displays all currently active alarms in RED. Detailed alarm status and alarm history can be found in the “Status” screen that will be displayed by pressing the “Status” button at the bottom of the screen.

5.2 Setup Screen Overview

The setup panel organizes all setup parameters into specific groups. These groups are accessed using the “Parameter Group” buttons located at the top of the setup screen. It should be noted that all parameters are password protected to provide “READ ONLY” access to control parameters. It is not possible to change system parameter setting if not logged into the system.

Login Permissions

The EndoInjectorV6 software provides 3 levels of access to the system configuration setup screen.

USER LEVEL (Default = 2): Provides access to standard system set points and tuning variables.

ADMINISTRATION LEVEL (Default = 22): Provides access to critical control parameters and alarm setpoint variables.

ENGINEERING LEVEL (Contact UPC): Provides access to configuration modes and controller setup functions.



Ratio Setup Parameter Group (USER, ADMIN, ENG Levels)

These parameters define the control of the air/gas mixing function of the EndoInjector. Changes to these parameters will take effect immediately. All parameters are only editable in USER, ADMIN, and ENG levels.

Maximum Ratio Set Point (Default = 3.00)

Maximum Air/Gas Ratio to be introduced when dew point control output is equal to 100%. The default setting of 3.00 may differ slightly due to specific generator characteristics. If the dew point is too low and the trim signal is 100% then the Maximum Ratio Set Point should be increased to provide proper dew point control. NOTE: Do not set this value above 3.50 as excessive water vapor may be produced within the generator retorts. If the required air/gas ratio approaches 3.50 this could indicate a probe sensor failure or “sooting” of the catalyst within the retort. Consult the generator manual for troubleshooting guidelines or contact UPC for further support.



Minimum Ratio Set Point (*Default = 2.50*)

Minimum Air/Gas Ratio to be introduced when dew point control output is equal to 0%. The default setting of 2.50 may differ slightly due to specific generator characteristics. If the dew point is too high and the trim signal is 0% then the Minimum Ratio Set Point can be decreased to provide proper dew point control. NOTE: Do not set this value below 2.00 as excessive “sooting” may occur within the generator retorts. If the required air/gas ratio approaches 2.00 this could indicate a probe sensor failure or water collection within the gas sample line. Consult the generator manual for troubleshooting guidelines or contact UPC for further support.

Endo Expansion Factor

Change the expansion factor used to calculate endothermic gas output flow rate. Endo Flow is a calculated value that represents the amount of endothermic gas being produced by the generator. It is calculated using the following equation: $\text{Endo Flow} = (\text{Air Flow} + \text{Gas Flow}) \times (\text{Expansion Factor})$. Typical values for systems using natural gas = 1.43, and for systems using propane gas 1.52.

Valve Speed Gain / Capacity (*FACTORY SET*)

This value defines the response characteristics of the fuel injection control valve. Typically, once this value is set at the factory, it will not require adjustment. Note: as a “rule of thumb” increasing this value will make the valve respond slower.

Ratio Deviation Alarm / Delay (*Default = 0.10 / 30sec*)

This value defines the limit for the ratio deviation alarm and the time required outside of this range before an alarm is sounded. When the actual air/gas ratio deviates from the ratio setpoint by more than this value for more than the delay time a Ratio Deviation Alarm will occur.

Dew Point Setup Parameter Group (*USER, ADMIN, ENG Levels*)

These parameters define the dew point control for the gas being produced by the gas generator. Changes to these parameters will take effect immediately. All parameters are only editable in USER, ADMIN, and ENG levels.

Dew Point Setpoint

The dew point setpoint is the desired dew point of the generated endothermic gas.

Dew Point Deviation Alarm / Delay

The deviation alarm value determines when a dew point deviation alarm should be triggered.

Control Mode (*Auto/Manual*)

The control mode defines the PID control active status for the dew point control loop. Typically, this parameter is left in “AUTO” mode but can be changed to “Manual” mode during system startup to “lock” ratio control at one ratio setpoint to season catalyst or lean out generator.



Control Output (%)

The control output in the dew point setup panel is the same as the %output as detailed on the dew point detail panel on the main screen. The value is READ ONLY when dew point PID control is in AUTO mode. However, the %Output can be changed when PID is in MANUAL mode.

Control PID Values

PID settings can vary widely depending on the controller hardware incorporated with the system. If not familiar with the controller setup parameters for that hardware, contact UPC for advice regarding initial settings and tuning recommendations.

Probe BO Interval (min) (Probe Only)

Time between each automatic probe burnout.

Probe BO Time (sec) (Probe Only)

Time to introduce burnout air to the probe.

Probe BO Delay (sec) (Probe Only)

Time to wait after stopping the burnout air before using the probe for automatic dew point control.

H Factor (Probe Only)

The H Factor represents the presumed hydrogen amount contained in the endothermic gas. Typically, this value is set to 400 (representative of 40.0% hydrogen). The H Factor parameter is used to calibrate the dew point value calculation for zirconia oxygen sensors. Increasing the H Factor by 10 will cause approximately a 1degF offset in the dew point reading.

Temperature Setup Parameter Group (USER, ADMIN, ENG Levels)

These parameters define the characteristics of the temperature control for the gas generator. Changes to these parameters will take effect immediately. All parameters are only editable in USER, ADMIN, and ENG levels.

Temperature Setpoint

The temperature setpoint is the desired temperature to control the gas generator hot zone.

Temperature Deviation Alarm / Delay

The deviation alarm value determines when a temperature deviation alarm should be triggered.

Control Mode (Auto/Manual)

The control mode defines the PID control active status for the temperature control loop. Typically, this parameter is left in "AUTO" mode but can be changed to "Manual" mode during initial system startup or for troubleshooting reasons. It should be fully understood that when the loop is in manual mode, the temperature is not under control and can go higher than desired. It is always recommended to check the over/low temperature controller (not included with



EndoInjector™ system) prior to placing temperature PID in manual mode to ensure temperature will shut down if excessive temperature is reached.

Control Output (%)

The control output in the temperature setup panel is the same as the %output as detailed on the temperature detail panel on the main screen. The value is READ ONLY when temperature PID control is in AUTO mode. However, the %Output can be changed when PID is in MANUAL mode.

Control PID Values

PID settings can vary widely depending on the controller hardware incorporated with the system. If not familiar with the controller setup parameters for that hardware, contact UPC for advice regarding initial settings and tuning recommendations.

Pressure Setup Parameter Group (USER, ADMIN, ENG Levels)

This parameter group is only available when pressure control is enabled from the system setup screen. The pressure control feature can only be used on “LP Configuration” systems that utilize Variable Frequency blower motor controls. Changes to these parameters will take effect immediately. All parameters are only editable in USER, ADMIN, and ENG levels.

Pressure Setpoint

The pressure setpoint is the desired generator outlet pressure the system should maintain

Pressure Deviation Alarm / Delay

The deviation alarm value determines when a pressure deviation alarm should be triggered.

Control Output (%)

The control output in the temperature setup panel is the same as the %output as detailed on the temperature detail panel on the main screen. The value is READ ONLY when temperature PID control is in AUTO mode. However, the %Output can be changed when PID is in MANUAL mode.

Control PID Values

PID settings can vary widely depending on the controller hardware incorporated with the system. If not familiar with the controller setup parameters for that hardware, contact UPC for advice regarding initial settings and tuning recommendations.

Blower Min Hz

Set the minimum speed that the blower should be allowed to run. This setting is used to set a base minimum flow rate through the generator. This value should be set at the frequency where the output flow is approximately 20% of rated generator capacity. Therefore, if output demand is reduced further, then the system will not allow the blower to spin slower and the output pressure will rise allowing for a relief regulator to open. The setup should provide that the flow through the EndoInjector™ mixing system is not below 20% of rated capacity.



Blower Max Hz

Set the maximum speed that the blower should be allowed to run. The setting can be set to the frequency that provides the maximum flow capacity of the generator. Thus, if additional demand is required, the blower will not increase in speed further than this value so that the system does not produce more endothermic gas than the system was designed for.

5.3 Language Setup Parameter Group (*USER, ADMIN, ENG Levels*)

The EndoV6 HMI software is designed to be completely multi-language capable and can be changed while online. To change the language, select the flag of the country and all text and alarm messages will be in the predominant language of that country. If the language (or flag) desired is not found, contact UPC support team to request a language/flag addition to the HMI program.

5.4 Paperless Chart Recorder

Pressing the “Chart” button on the main screen opens the EndoInjector paperless chart recorder. The paperless chart recorder displays the long-term historical data for all generator process variables. Data is stored once every minute on the touch-screen hard drive in daily encrypted log files that can be exported to CSV files that can be opened in any spreadsheet program (i.e. MS Excel) for detailed investigation and reporting if required. The generator performance data will never overwrite old data since the hard drive space provides 50+ years’ worth of daily storage space. However, for tacking purposes, the data should only be considered archived for 5+ years on the touch screen unless backed up to a remotely maintained data storage center.



Paperless Chart Recorder Overview

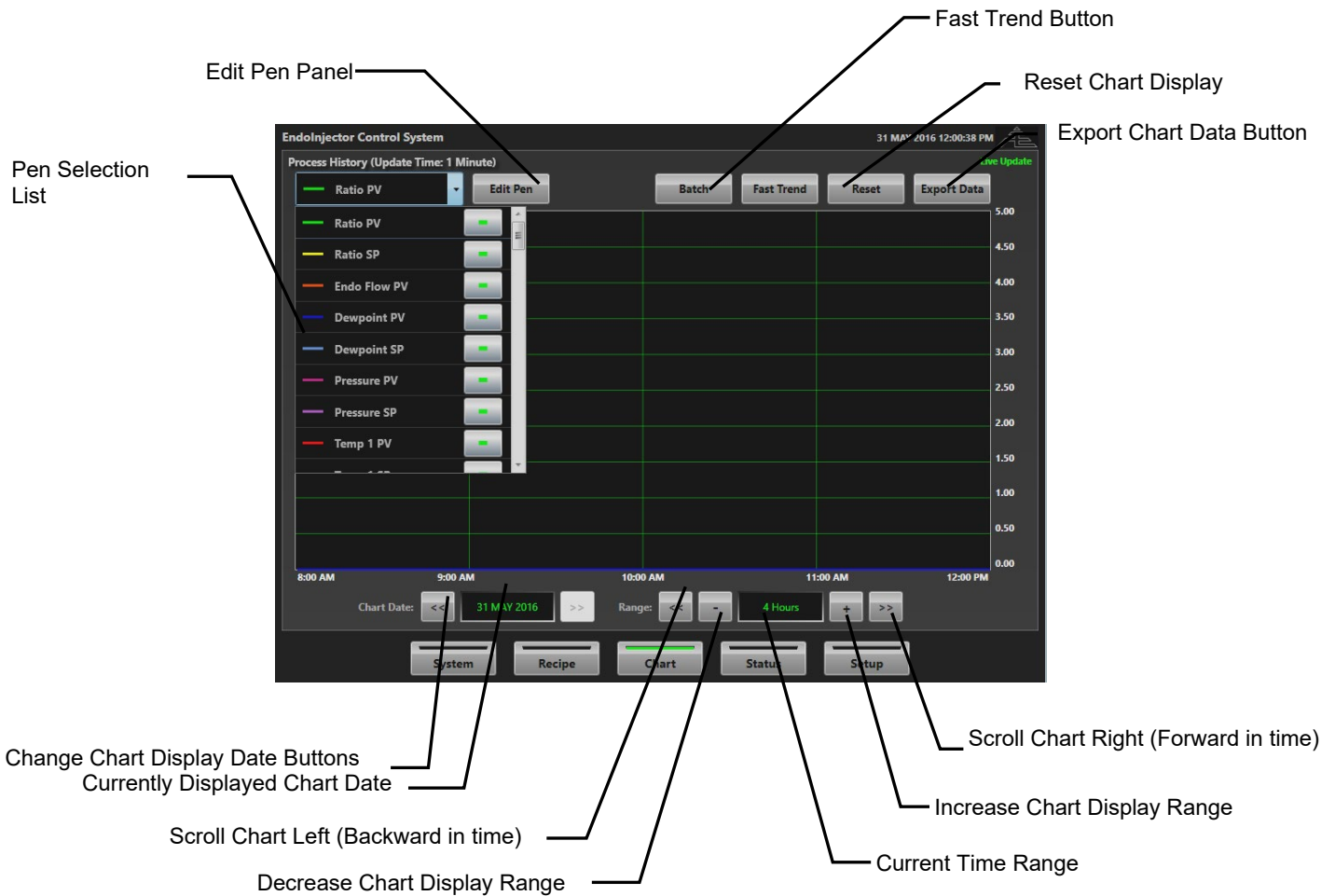

Pen Selection List

The pen selection list provides a list of all pens available to display, the current pen color for each variable, and a button to display or hide the pen on the chart. Also, selecting a pen will update the scale values on the right of the chart to display the selected pen's scale settings. Each pen is drawn based on their own minimum and maximum scale range. The scale range for each pen can be changed by first selecting that pen in the Pen Selection List and then pressing the "Edit Pen" button. Note: The actual data values are stored regardless of pen scale or display settings.

Edit Pen Button

The edit pen button opens a panel that provides a way to edit the minimum display scale range, maximum display scale range, and pen color selection. Note that each pen is drawn based to its own scale however, actual data stored is not affected by these settings.

Currently Displayed Chart Date



The log data is separated into daily log files. The log file that is currently being displayed is shown in the currently displayed chart date at the top of the chart.

Change Chart Display Date Buttons

The change chart display date buttons are located on either side of the current chart date at the top of the chart screen. Pressing these buttons will increase or decrease the current display date by one day.

Current Time Range

The current time range is found at the bottom of the chart display and represents the amount of time currently displayed from the left to the right on the chart. The default is to display 4 hours of data at a time but this can be increased to an entire day or decreased to just 15 minutes.

Increase / Decrease Chart Display Range Buttons (+ / -)

The increase and decrease chart display buttons will change the time range of data to display on the chart. Basically, these buttons provide a way to zoom in and out of the data in time. The limit is to increase the range to view an entire day of data or decrease the range to view just 15 minutes of data.

Scroll Chart Right / Left (<< / >>)

The scroll chart buttons provide the means to pan the chart through time. Each press of either of these buttons will scroll the chart by 2 vertical gridlines (1/2 of the time range displayed).

Fast Trend Button

The live data button indicates and provides a way to turn the chart display on or off so that it automatically updates while viewing the data. When the live button is “on” then the chart will update and scroll automatically from right to left as new data is written to the log file.

Reset Chart Display

The reset chart display will reset the current display date to “today” and the current time range to 4 hours.

Export Data Button

The export data button opens a save dialog window to export the currently displayed daily data to a csv file. Attach a USB storage device to one of the USB ports on the back of the touch-screen then navigate and save the csv file to the storage device so that it can be transferred to another computer for review.

5.5 Alarm Status Screen

Pressing the “Status” button on the main screen opens the alarm status screen that indicates current system alarm status.

The visibility of some alarms depends on what alarms are enabled on the system and available on the controller installed.



The lists of alarms will turn green, yellow, or red depending on status of the alarm being described.

Red = Active alarm that has not been acknowledged

Yellow = Active alarm that has been acknowledged

Green = Alarm is OK

Grey = Alarm is not active

Communication Alarm Status

COM alarms occur when any failure of the Modbus communication is detected. All other alarms will remain “Black” until all communication alarms are resolved as OK.

HMI Serial Port

A port open alarm occurs when the com port selected in the setup screen is not actually found on the HMI touch screen. Also, if the communication port of Ethernet is selected then a port alarm will occur when the IP address the HMI is trying to reach to communicate with the ratio controller is not found.

Device Connection

A ratio controller communication alarm occurs when the ratio controller cannot be found or a Modbus read or write operation has failed. Typically, this alarm will occur if the polarity of a serial connection is reversed or disconnected.

Mixing System Alarms

Air / Gas Sensor Signal

Indication that air or gas sensor is outside normal 4-20mA range

Ratio Deviation

Indication that air/gas ratio is outside the deviation band for more than the alarm delay period.

High Ratio

Indication that air/gas ratio is above the high ratio alarm setpoint for more than the alarm delay period.

Endo Flow Low

Indication that calculated endo gas flow is below or above the alarm setpoint for more than the alarm delay period.

EndoInjector™ Blower

Indication that the blower is not in operation.

Pressure Deviation



Indication that pressure is outside the deviation band for more than the alarm delay period.

Dew Point Deviation

Indication that dew point is outside the deviation band for more than the alarm delay period.

Fire Check Valve

Indication that the fire check valve switch is ok.

Vent Pilot Flame

Indication that the vent pilot flame safety is OK. This flame must be present during the mixing system operation.

Retort(s) Alarms

Over Temperature

Indication that the over temperature controller for that retort is tripped open.

Low Temperature

Indication that temperature of the retort is below the low temperature alarm setpoint.

Temp Deviation

Indication that temperature of the retort is outside the deviation band for more than the alarm delay period.

Output Temperature / Endo Temperature

Indication that endothermic gas temperature is above the endo temp alarm setpoint. This is an indication that the cooler may not be in operation or requires maintenance.

5.6 Recipe Screen

For full details on recipe screen operation refer to the ActivePLC Operation Manual
Please contact UPC with questions.



6 CUSTOMER SUPPORT

Americas	Asia	Europe
<u>support.na@upc-marathon.com</u>	<u>service@mmichina.cn</u>	<u>support.eu@upc-marathon.com</u>
USA: +1 414 462 8200	Shanghai: +86 21 3463 0376	France: +33 3 81 48 37 37
Canada: +1 514 335-7191	Beijing: +86 10 8217 6427	Germany: +49 7161 94888-0
		Poland: +48 32 296 66 00

Reach us at www.upc-marathon.com

UPC-Marathon brings together leading brands to the heat-treating industry including Atmosphere Engineering, Furnace Control, Marathon Monitors, Process-Electronic, and Waukee Engineering. We provide prime control solutions through our worldwide sales and services network with easy-to-access local support.

